

The post and panel system with CSM-200 comes in three different models: 218, 225, and 250

These models are made of aluminum, which makes them durable enough to withstand longterm outdoor use. Choose from both Single and Double Panel options.

Additionally, the 325 and 750 series profiles can be interchanged with these models, giving you more options. This high quality two-inch system is flexible, cost-effective and easy to assemble.

The signage has a uniform appearance, which provides a consistent look and feel to your customers.

FINIALS

Standard finial options available on 218, 225, 250, 325 and 750 series.

USED FOR

Wayfinding Signs | Secondary Signs
Parking Signs | Regulatory Signs

BENEFITS

- **Depth:** 2"
- **Face Panel(s):** Single .100 or .125
- **Sizes:** Panel range 12"- 48"h x 12"-72"w
- **No Frame:** Slotted Post
- **Posts Sizes - See Post Options**
2" sq
3-1/4" sq
3-5/8" round
- **Colors:** Custom Painted or Mill Finish
- **Graphics:** Order with or without

LEAD TIME/WARRANTY

Assembled-Painted - 10 Working Days
Quick Ship

Unassembled-Unpainted - 3 business days

Unassembled-Painted - 5 business days

Warranty - 1 year - Designed for long-term outdoor use.



SERIES 200 CUSTOM DESIGN OPTIONS



225 STANDARD POST / CENTER MOUNT PANEL



218 SQUARE POST



225 STANDARD W/REVEAL

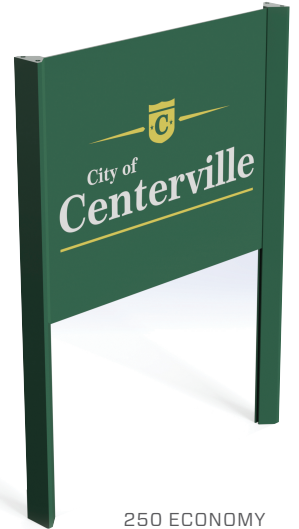

250 ECONOMY

SERIES 218 COMPONENTS

POST OPTIONS »

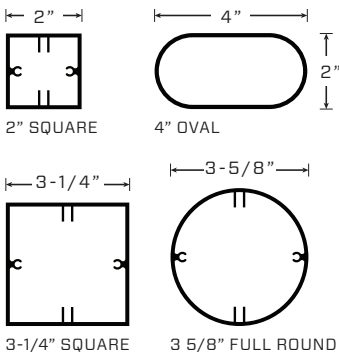

SERIES 225 COMPONENTS

POST OPTIONS »

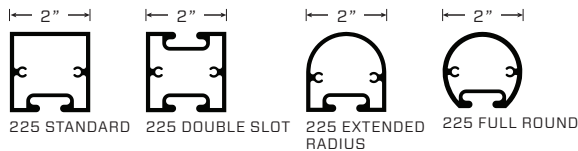

FRAME OPTIONS »



SERIES 250 COMPONENTS

POST OPTIONS »

ALL SERIES 325 POSTS. SEE PAGE 6 OF OUR CATALOG.

FRAME OPTIONS »

