

SERIES 325

THE SERIES 325 POST AND PANEL SYSTEM

The 325 Series is the most versatile component of the Charleston Manufacturing, LLC family of architectural signage systems. The 325 System is designed for non-illuminated exterior use and is intended for primary site identification and directional information. Single face or double face copy may be specified.

The designer may select rectangular, radius or full-round posts. Corner posts allow for perpendicular signage or may be easily adapted for four-sided signage. Posts are available in lengths up to 24'. Standard posts are 8', 12' and 24'. Allow for 3' minimum below grade.

All Series 325 components are finished after fabrication, thereby eliminating bare edges and ensuring a uniform appearance. Standard 325 finishes include fifteen standard colors in acrylic polyurethane. Custom colors and color matching are available within standard lead times.

The 325 Series is available preassembled or in knock-down form for easy assembly on-site. Graphics may be furnished by Charleston Manufacturing, LLC Industries or by the installer.

FLUSH FACE DESIGN

As an option, the 325 Series is available with a "flush face" panel that lends a frameless appearance to the sign.

325 FLUSH FACE FRAME WITH REVEAL

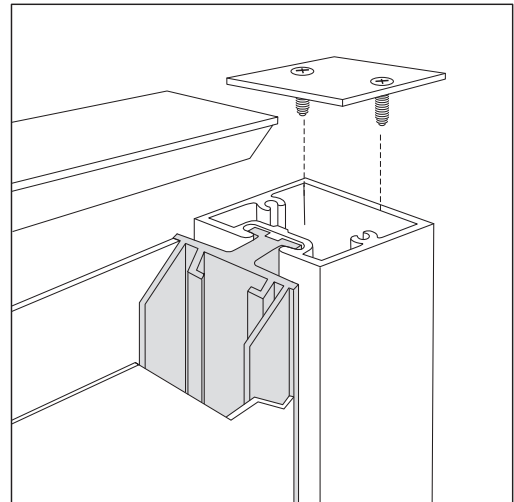
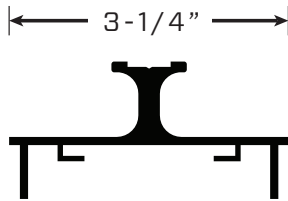

SERIES 325 CUSTOM DESIGN OPTIONS



EZ SLIDE



CEILING MOUNT w/RADIUS CORNERS



FULL ROUND POST & PANEL /
FINIALS / CUSTOM TOP



DOUBLE FLAG